

FRTSvg 7521

Liebherr Refrigerator table with dynamic cooling and stainless steel worktop

Self
Closing
Door

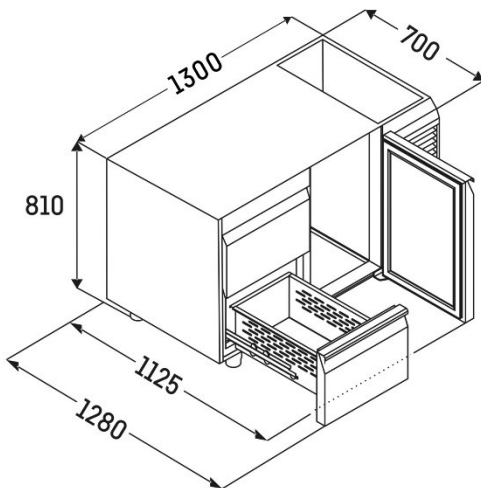

Climate Class	5
Exterior dimensions W/D/H	130 /70/81 cm
Energy Efficiency Class	A
Energy Consumption per year	563 kWh/a
Noise level	56db
Refrigerant	R 290
Ambiant Temp	+10C to 40C
Connection rating	1.15 A
Voltage	220-240V
Frequency	50Hz
CONTROLS AND FUNCTIONS	
Control Unit	Electronic Control Unit
Temperature Display	Touch
Warning Signal	Optical
Smart Monitoring Enabled	-
Refrigerator Compartment	
Gross Volume/Net Volume	280L/180L
Temp Range	-2 C to +8C
Cooling System	Dynamic
Defrosting	Automatic
No of Shelves	6
DESIGN AND MATERIAL	
Colour and Material	Stainless steel
Handle	Handle moulding
Interior	Chrome-Nickel steel AISI 304
Shelf	Plastic-coated grids
Self-Closing Doors	Yes
Door Hinges	left fix/right fix
Number of compartments	2
Compartment 1	Door
Compartment 2	Door
Door hinge replacement	Possible for customer
Packaged Dim W/D/H	139.5/80/99 cm
Weight without Packaging	138/120 kg
/Weight with Packaging	

LIEBHERR

Please note: despite careful data management, we reserve the right to make technical changes; and discrepancies may occur between the image or text content and the original appliance